

W Winkel-Stutzen

EO 24°-Anschluss

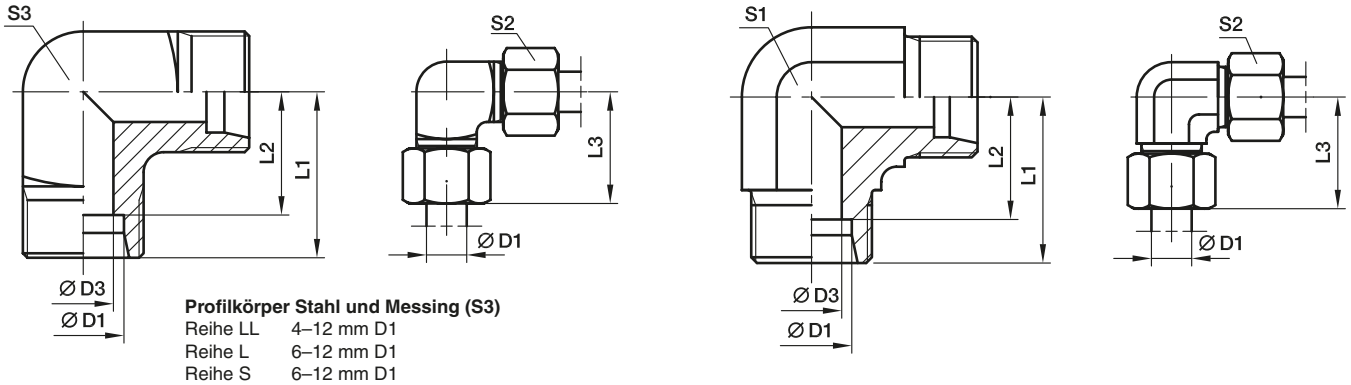

| Bau- reihe | D1 | D3 | L1 | L2 | L3 | S1 | S2 | S3 | Gewicht g/St. | Bestellzeichen* | PN (bar) ¹⁾ | | |
|------------------|----|------|----|------|----|----|----|----|------------------|-----------------|------------------------|-----|-----|
| | | | | | | | | | | | CF | 71 | MS |
| LL ²⁾ | 04 | 3,0 | 15 | 11,0 | 21 | 9 | 10 | 9 | 13 | W04LL | 100 | 100 | 63 |
| | 06 | 4,5 | 15 | 9,5 | 21 | 9 | 12 | 11 | 15 | W06LL | 100 | 100 | 63 |
| | 08 | 6,0 | 17 | 11,5 | 23 | 12 | 14 | 12 | 23 | W08LL | 100 | 100 | 63 |
| | 10 | 8,0 | 18 | 12,5 | 24 | 12 | 17 | 14 | 32 | W10LL | 100 | 100 | 63 |
| | 12 | 10,0 | 19 | 13,0 | 25 | 14 | 19 | 17 | 41 | W12LL | 100 | 100 | 63 |
| L ³⁾ | 06 | 4,0 | 19 | 12,0 | 27 | 12 | 14 | 12 | 29 | W06L | 500 | 315 | 200 |
| | 08 | 6,0 | 21 | 14,0 | 29 | 12 | 17 | 14 | 43 | W08L | 500 | 315 | 200 |
| | 10 | 8,0 | 22 | 15,0 | 30 | 14 | 19 | 17 | 54 | W10L | 500 | 315 | 200 |
| | 12 | 10,0 | 24 | 17,0 | 32 | 19 | 22 | | 80 | W12L | 400 | 315 | 200 |
| | 15 | 12,0 | 28 | 21,0 | 36 | 19 | 27 | | 81 | W15L | 400 | 315 | 200 |
| | 18 | 15,0 | 31 | 23,5 | 40 | 24 | 32 | | 140 | W18L | 400 | 315 | 200 |
| | 22 | 19,0 | 35 | 27,5 | 44 | 27 | 36 | | 178 | W22L | 250 | 160 | 100 |
| | 28 | 24,0 | 38 | 30,5 | 47 | 36 | 41 | | 340 | W28L | 250 | 160 | 100 |
| | 35 | 30,0 | 45 | 34,5 | 56 | 41 | 50 | | 458 | W35L | 250 | 160 | 100 |
| | 42 | 36,0 | 51 | 40,0 | 63 | 50 | 60 | | 776 | W42L | 250 | 160 | 100 |
| S ⁴⁾ | 06 | 4,0 | 23 | 16,0 | 31 | 12 | 17 | 14 | 52 | W06S | 800 | 630 | 400 |
| | 08 | 5,0 | 24 | 17,0 | 32 | 14 | 19 | 17 | 74 | W08S | 800 | 630 | 400 |
| | 10 | 7,0 | 25 | 17,5 | 34 | 19 | 22 | | 97 | W10S | 800 | 630 | 400 |
| | 12 | 8,0 | 29 | 21,5 | 38 | 17 | 24 | 22 | 137 | W12S | 630 | 630 | 400 |
| | 14 | 10,0 | 30 | 22,0 | 40 | 19 | 27 | | 145 | W14S | 630 | 630 | 400 |
| | 16 | 12,0 | 33 | 24,5 | 43 | 24 | 30 | | 162 | W16S | 630 | 400 | 250 |
| | 20 | 16,0 | 37 | 26,5 | 48 | 27 | 36 | | 221 | W20S | 420 | 400 | 250 |
| | 25 | 20,0 | 42 | 30,0 | 54 | 36 | 46 | | 424 | W25S | 420 | 400 | 250 |
| | 30 | 25,0 | 49 | 35,5 | 62 | 41 | 50 | | 603 | W30S | 420 | 400 | 250 |
| | 38 | 32,0 | 57 | 41,0 | 72 | 50 | 60 | | 1010 | W38S | 420 | 315 | 200 |

¹⁾ Druckwert genannt = Artikel lieferbar
²⁾ LL = Sehr leichte Baureihe; ³⁾ L = Leichte Baureihe; ⁴⁾ S = Schwere Baureihe

$\frac{PN \text{ (bar)}}{10} = PN \text{ (MPa)}$

*Ergänzen Sie bitte die Bestellzeichen mit den **Kennbuchstaben** für das gewünschte Material.

| Bestellzeichen-Ergänzungen | | |
|------------------------------|--|----------|
| Material | Kennbuchstaben Oberfläche und Material | Beispiel |
| Stahl, verzinkt, Cr(VI)-frei | CFX | W16SCFX |
| Edelstahl | 71X | W16S71X |
| Messing | MSX | W16SMSX |

